



The DAF XF105



Built for the long haul





The XF105: comfort, power and performance

Built for the long haul

Low operating costs, best driver satisfaction and high reliability: the key development criteria behind DAF's trucks for the long haul. The XF105 is the best proposition on the market today. It has the most spacious cab in its class, offers top comfort to the driver and high revenues per kilometre to the operator. It's a top performer.

Designed for long distance haulage applications, the cab sets the highest standard for driver comfort. With a choice of Space Cab and Super Space Cab – both with generous interior dimensions – the XF105 offers more living, working and storage space than any other truck in its class. The result: drivers stay fit and alert longer.

Powered for profit

The 12.9-litre PACCAR MX engine delivers excellent performance: from 410 hp up to 510 hp and high torque of between 2,000 and 2,500 Nm, with a maximum torque available between 1,000 and 1,410 rpm. Also, with DAF SCR Technology it complies with Euro 5 and EEV* exhaust gas emission standards. It is economical too, incorporating several technical advances that reduce fuel consumption. The XF105 also uses many low-maintenance components, which extends service intervals to further reduce operating costs.

High performance driveline

The driveline is carefully balanced to optimise performance under all operating conditions, and to make the most of the engine's low fuel consumption. There is a choice of either a 12- or 16-speed manual gearbox or the latest AS-Tronic automated transmission to deliver power to the acclaimed DAF hypoid rear axle. There is also a hub-reduction axle for more demanding applications.

Choice of axle configurations

To ensure that the XF105 is ideally suited to each application, it includes a choice of tractors and rigids with two, three or four axles.

* Enhanced Environmentally-friendly Vehicles



Evolution rather than revolution

Functionality meets design

Evolution rather than revolution, was the starting point for DAF's flagship truck. The DAF Design Centre gave the XF105 a remarkable, unique and stylish appearance, while maintaining all its distinctive functional aspects.

The XF105 has numerous styling and aerodynamic refinements. They include a stylish lower grille, which extends to the bumper and is more pronounced to channel more air and enhance performance. The lower grille also features an aluminium strip to signify compliance with the Euro 5 and EEV exhaust emission standards, while the upper grille is designed with cleaner lines. There is also a styled bumper in which optional cat's-eye combi-lights can be integrated. The clear headlamps with virtually unbreakable Lexan protection are also available as Xenon.

Wide field of vision

The four large, electrically adjustable and heated mirrors offer a large field of view for increased safety. The stylish aerodynamically designed mirrors are optionally available in cab colour.

Super Space Cab roof

The Super Space Cab roof is both pronounced and stylish. There is an integrated aerodynamic sun visor. While the optional integrated skylights, with twin 70W halogen spotlights, improve visibility and add an extra touch of style. It all adds up to a unique, powerful presence, both tough and inviting at the same time.

The one-piece GRP roof is supported by a strong bolted steel frame and complies with the most severe safety regulations for cabs.



Exterior elements like the cat's-eye combi-lights, adjustable heated mirrors, Skylights and Xenon headlights all combine aerodynamic properties with a stylish design.

Strong, imposing and impossible to ignore.



Comfort with style

High standards of interior design

The XF105 sets high standards when it comes to interior design. High standards in the materials and colours which have been chosen, high standards in space and its use, high standards in quality, finish and ergonomics.

The driver was always the most important consideration during the design programme for the XF105. That's true of the attractive door trim to the modern instrument panel, from the logically-positioned handles and switches to the steering wheel that drivers consider to be 'the one that fits best', right through to the fold-away gear lever. It's true too in the case of the numerous smart storage facilities through to the amber-tone indirect night lighting right across the floor and in the central storage tray.

The best possible standards for the driver

In every respect, the interior has been designed to provide the best possible standards for the driver. Working and living in this cab is a pleasure. An exclusive, two-tone interior adds the touch of luxury to the Super Space Cab. Right down to the minutest detail, the wishes and working conditions of the driver have been given top priority.





Designed to provide the very best working and living space

Safe, comfortable control

Sit in the driver's seat, behind the ergonomically designed steering wheel and it immediately becomes clear that safety, comfort and ease of operation were given high priority during the development of the XF105. Features such as Adaptive Cruise Control, Forward Collision Warning and DAF Camera System - make driving even safer and more comfortable.

The thick-rimmed four-spoke steering wheel ensures a comfortable grip and clear view of the dashboard instruments. An airbag in the steering wheel is available as an option. Also optional are the illuminated integrated switches that operate cruise control, downhill speed control and the hands-free telephone function. Other key operating functions, including those for the AS-Tronic gearbox, are controlled via easy to operate steering column stalks. Controls on the dashboard as well as the controls for the four large mirrors and window operation on the door console are all back-lit and can be clearly seen at all times.

Information at-a-glance

The main gauges on the modern instrument panel provide information on primary functions, while the central information display presents other essential vehicle information, but only when needed or on the driver's request. This ensures that the driver is not unnecessarily distracted, but can still receive relevant information. The LCD offers a choice of 32 different languages, and also provides information on trip duration, average speed and PTO hours.

To challenge the driver to the most fuel efficient driving style, information on the actual and realized fuel consumption is given on the display integrated in the instrument panel. Comprehensive trip fuel information is available after engine shutdown for further evaluation.

Computer and phone connections

In addition to the usual dashboard features there are three DIN slots, one above the other. These allow easy installation of not only an audio system but also a navigation system, camera display or on-board computer. There is also an optional docking station for a mobile phone, which is pre-wired for hands-free connection through controls on the steering wheel. Switches for other functions, including those for the high-capacity heating and ventilation system - with optional automatic temperature control (ATC) - are all located within easy reach.

A preparation for a Fleet Management System, comprising an FMS connector and a GPS antenna is standard on all XF105 vehicles.

Practical use of space, high quality materials and subtle lighting – unmistakably DAF.



Adaptable to drivers' needs; the steering wheel, optionally available in leather, is adjustable both for reach (85 mm) and angle (30° to 45°).



DAF

DAF

XTRA COMFORT

Class-leading interior space

The home away from home

The standing height on the engine tunnel is an impressive 175 cm in the Space Cab and an unprecedented 210 cm in the Super Space Cab – thanks to the lowered engine tunnel, which is just 15cm high, and prevents that of sand and dirt from the footwells being spread all over the cab floor.

Moving from behind the steering wheel to the sleeping area is easy. The gear lever can be folded away and is even entirely absent on the AS-Tronic version, so the driver has complete freedom of movement.

Outstanding sleeping comfort

The sleeping area features two spacious bunks. The lower bed (210 cm long, up to 81 cm wide) can be used as a comfortable sofa to sit at the table. The upper bunk is easily accessible via a fold-away aluminium ladder with extra-wide rungs that can be climbed in comfort even with bare feet. An easy-lift support system makes it a simple matter to fold away the top bunk. It has a handy facility for hanging a towel. An optional, 15 cm-thick, one-piece pocket spring 'Xtra Comfort' mattress (selected by drivers as giving the best level of comfort) is fitted as standard in the Super Space Cab. And a good night's rest is finally assured by the optional DAF Night Lock, which safeguards drivers against night-time intrusion.

Ample storage space

Beneath the bunk is space for large storage drawers, with an option for installing a 42-litre refrigerator drawer. There is also a standard bottle holder mounted within easy reach of the driver's seat. Many of the other lockers have adjustable partitions, power sockets and can hold, e.g. a microwave oven, or a TV or coffee machine. It's truly a home away from home.

Refined interior illumination

Relaxing amber-tone indirect night lighting illuminates the floor and central storage tray. And in the Super Space Cab, lighting is fitted in the roof console.

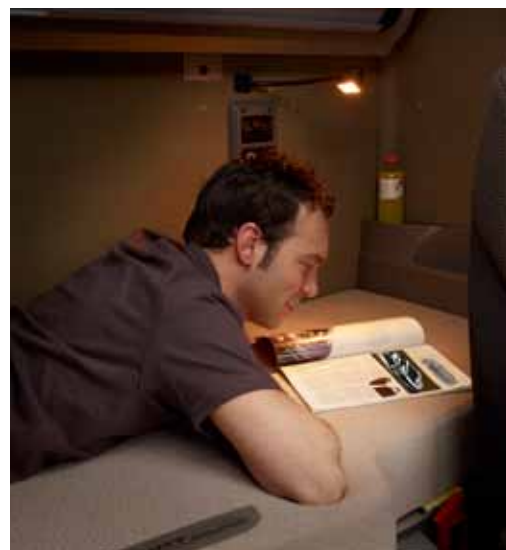

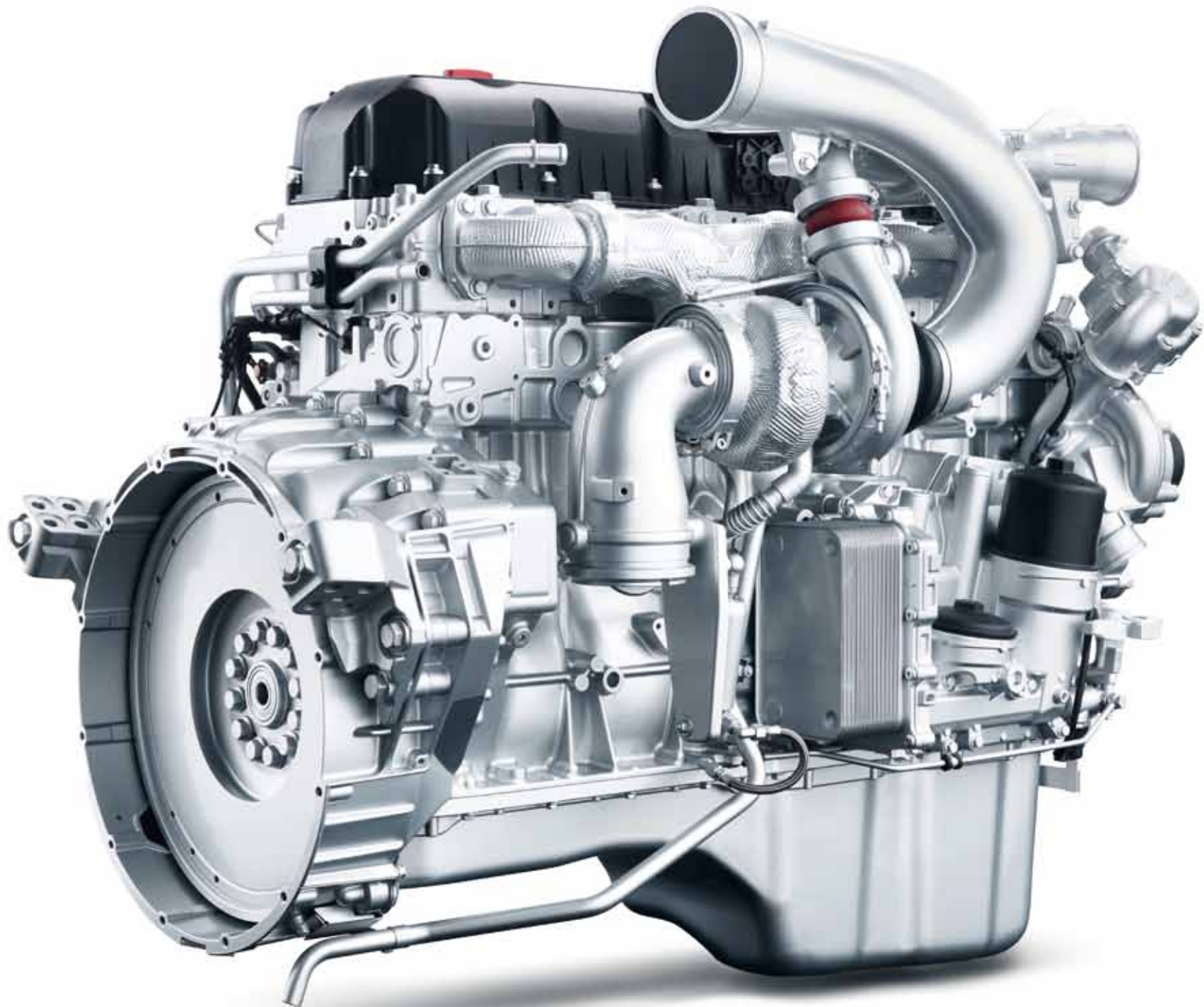

A range of efficient engines

The power to perform

The PACCAR MX engine, developed and manufactured by DAF, combines excellent high performance with economical fuel consumption. It is available in 410, 460 and 510 hp versions with high torque of 2,000, 2,300 and 2,500 Nm respectively. Importantly, maximum torque is available between 1,000 and 1,410 rpm.

The MX engine complies with Euro 5 and EEV emission standards, thanks to the SMART injection system and DAF SCR Technology. The MX engine can be specified with an excellent integrated engine brake, offering a braking performance from 210 kW at 1,500 rpm to 320 kW at 2,100 rpm.

Longer service intervals

The engine design results in longer service intervals starting from 90,000 km. Moreover, with a centrifugal filter and the use of synthetic oil, intervals of up to 150,000 km can be achieved, resulting in lower operating costs and maximum vehicle availability. In addition, the use of high-quality materials such as Compact Graphite Iron for the cylinder block and cylinder head further improve reliability. While extensive

function integration results in excellent reliability and durability. The inlet manifold, for example, is integrated in the cylinder head, and the oil filter, oil thermostat and oil cooler are combined in a single oil lubrication module. In fact, there are 25% fewer parts in this engine, which dramatically increases reliability and prolongs lifetime.

Lower operating costs

Integration also results in lower operational costs – maintenance is simpler, faster and therefore less expensive and there are fewer parts that wear and need periodic replacement. Add to that the longer service intervals of up to 150,000 km and the PACCAR MX engine offers low cost of operation.



Above: the cable harness is coated in rigid foam and is securely fitted so that its weight no longer hangs on the connectors. This eliminates stresses on the connectors and increases reliability. In addition, the ECU does not require separate cooling, which means further parts reduction, more reliability.

Below: the oil filters, the oil thermostat and oil cooler are integrated into one lub-oil module. This is a revolutionary design and industry first, and helps optimise reliability by minimising parts.

Performance, reliability and fuel economy.

Efficiency, low cost of operation and care for the environment

DAF Advanced Transport Efficiency



DAF ATe Range

DAF Advanced Transport Efficiency (ATe) consists of a full range of solutions with the aim of increasing transport performance while further reducing environmental impact and costs.

Evolution never stops. To extend its leading position in the field of fuel efficiency and low operating costs even further, DAF has introduced a significant number of innovations to the successful 12.9 litre PACCAR MX engine. New pistons, optimised fuel injection and a unique, fully encapsulated exhaust manifold unit ensure substantially lower fuel consumption and therefore lower CO₂-emissions.

Speed limiter

The speed limiter setting does not allow vehicle speeds over 85 km/h. Compared to the customary setting at a maximum speed of 89 km/h, this saves up to 3% fuel in long distance transport applications.

Engine idle shutdown

The engine idle shutdown system automatically stops the engine after it has been idling for 5 minutes, preventing wastage of fuel and reducing emissions. The engine idle shut down is standard on all XF105 vehicles.

Extensive fuel consumption information

To challenge the driver to the most efficient driving style, information on the actual and realized fuel consumption is given on the display integrated in the instrument panel. After engine shutdown comprehensive trip fuel information is available for further evaluation.



ATe

High performance and low fuel consumption

A driveline that's perfect for your unique needs

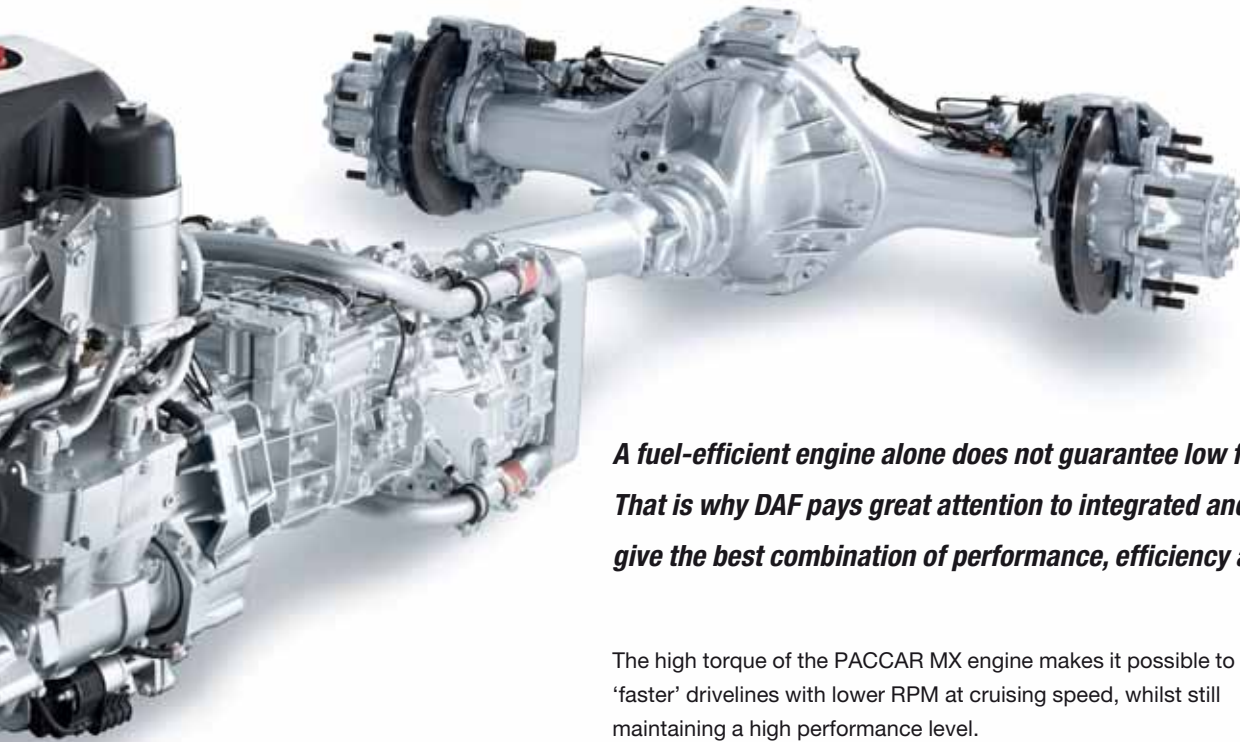

A fuel-efficient engine alone does not guarantee low fuel consumption; the gearbox and rear axle are also vitally important. That is why DAF pays great attention to integrated and optimal driveline technology. A new Intarder, plus faster rear axle ratios give the best combination of performance, efficiency and low weight.

The high torque of the PACCAR MX engine makes it possible to create 'faster' drivelines with lower RPM at cruising speed, whilst still maintaining a high performance level.

Wide choice of axle ratios

The XF105 series offers a wide choice of rear axle ratios, including the fast 2.80, 2.69 and 2.53 ratios. The extra fast rear axle ratios allow for lower average engine speeds for the best achievable fuel efficiency.

Manual or automated

The DAF XF105 series provides a choice of manual or automated gearboxes. The standard manual gearbox has 12 speeds. A 16 speed-manual gearbox is available as an option. Thanks to the 'Servoshift' gear-change device, forces are extremely low and changing gear takes very little effort. For higher comfort and efficiency, the AS-Tronic automated gearshift, with either 12 or 16 speeds, offers state-of-the-art shifting behaviour. The AS-Tronic is now also available with different software settings for heavy haulage, tank and off-road applications. This enables the driver to fully concentrate on the road while also increasing the lifetime of the clutch.



XF

DAF

XF

XF105
XF105

Higher productivity by design

A solid foundation

The XF105 has a highly compact chassis layout, one that cleverly integrates the exhaust silencer, battery carrier, up to 100 litre AdBlue tank, and dosing unit all into one module. Also, by designing the air tanks and brake components layout on the inside of the chassis, space has been created for extra large fuel tanks. The two axle executions can be supplied with a fuel tank capacity of up to 1,500 litres, which allows refuelling at the home base, or where it best suits the operation.

The robust XF-chassis is made of high quality steel, resulting in an exceptionally strong but lightweight chassis for high payloads.

Two-, three- and four-axle tractors

Different types of factory-installed fixed or sliding fifth wheels are available for all XF105 tractor models. For transportation of large volumes, DAF can supply a 4 x 2 tractor version that has an extremely low fifth wheel height of only 96 centimetres. This means that trailers with an internal height of nearly three metres can be used for load volumes of up to 100 m³. This so called Low-Deck tractor has a 7.5-tonnes front axle with parabolic springs and an 11.5-tonnes rear axle with a four-bellow air suspension. A front axle with air suspension is also available as an option. For additional payload capacity, a range of 6 x 2 chassis are available. The twin steer 6 x 2 model comes with a steered and liftable rear axle. An important advantage of this leading rear axle is its high yard friendliness. For special, light- or heavy-duty applications, the 6 x 2 tractors are available with liftable trailing axle with single or double mounting. For operators who need a limited amount of additional payload, DAF can supply the XF105 with a light and non-steered liftable leading axle with 17.5" wheels.

To complete the tractor range, a 3-axle tractor and a 4-axle tractor with double drive are available – especially suitable for heavy haulage.

Wide range of rigids

The XF105's chassis frame is completely flat, making it the perfect base for any superstructure. To make the body builder's job as easy as possible, the main frame members are pre-drilled to ensure easy mounting of the body. A Body Builder's Module (BBM) can also be provided to facilitate communication between the electric systems of vehicle and body.

DAF supplies the XF105 rigid as a standard 4 x 2 model with a wide choice of wheel bases. There is also an extended range of 6 x 2 rigids. All trailing-axle versions have air suspension and are available with single or double mounted tyres. Air suspension at the front is optional. The XF105 is also available as a 6 x 2 rigid with steered trailing rear axle for extra high manoeuvrability and yard-friendliness. The range has been completed with 6 x 4, 8 x 2 and 8 x 4 versions.



Quality and reliability for optimum productivity

A joy to drive

All in all, the DAF XF105 is the ultimate driver's truck – a thoroughbred driving machine. With a spacious, comfortable cab, that is well-equipped and beautifully finished in attractive materials and warm colours. It also offers a jewel of an engine delivering up to 510 hp and torque of 2,500 Nm for optimum pulling power and smooth ride.

The accurate steering characteristics mean excellent road holding for safe, comfortable driving. While the electronically controlled braking system, with disc brakes all around and 'Brake Assist**', optimises braking and safety.

In addition to its easy-to-use controls, the XF105 offers a whole range of optional comfort and safety-enhancing features. These include Adaptive Cruise Control, Forward Collision Warning, Vehicle Stability Control, Lane Departure Warning System, airbag in combination with seatbelt pre-tensioners, and DAF Camera System for maximum safety during tight manoeuvres.

Low running cost – high re-sale value

For the operator, the XF105 offers low running costs and high transport efficiency combined with quality and reliability for maximum availability. Long maintenance intervals and professional service from your DAF dealer minimise downtime to further reduce operating costs. The XF105 has also been developed for optimum durability, so that even after travelling many hundreds of thousands of kilometres with its first owner, it still offers a fabulous earning potential for the next. The result is of course a high residual value.

* *Brake Assist is an electronic system that recognises when an emergency brake is being made. It then instantly applies full braking power and therefore increases safety.*



Comfort and safety systems to rely on

DAF Trucks offers a wide range of comfort and safety options, which has been further enhanced for the XF105. The comprehensive list of comfort and safety features includes Adaptive Cruise Control and Forward Collision Warning. In addition, all DAF trucks are designed to offer industry-leading comfort and a best in class human-machine-interface, to keep the driver safely in control in the most comfortable way.

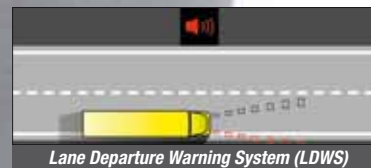

Electronic Braking System (EBS)

- Anti-lock Braking System (ABS)
- Anti-Slip Control (ASR)
- Brake assist
- Drag torque control
- Hill-start aid

Vision

- Front side view camera systems
- Front and electrically adjustable side view mirrors
- Kerb view mirror
- Xenon headlights

Drivers support systems

- Adaptive Cruise Control (ACC)
- Forward Collision Warning (FCW)
- Lane Departure Warning System (LDWS)
- Vehicle Stability Control (VSC)
- Axle Load Monitoring (ALM)

Passive safety systems

- Seat belt reminder
- Airbag and seat belt pre-tensioners
- Front and rear under-run protection



Committed to world-class

Right first time

DAF Trucks - A PACCAR Company - applies state-of-the-art technology to maintain the highest standards in development and manufacturing. Over the last few years, major investments have been made in all production facilities. DAF trucks are built in world-class facilities in Eindhoven (NL), Westerlo (B) and Leyland (UK), by dedicated people, using high-quality materials and efficient processes.

For the production of PACCAR engines, the engine factory has been totally renewed, making it one of the most modern of its kind in the world. In other factories too, major innovation programmes have been undertaken to achieve the highest efficiency and quality levels. DAF Trucks introduced the PACCAR Production System to achieve world-class manufacturing standards: everything right first time, with no unnecessary loss of energy or materials and with the highest conceivable quality. As a result, world-class products are produced in world-class factories.

Information Technology

DAF Trucks and its dealers have information technology systems that track a truck and its components throughout its entire life cycle – from design and production to aftermarket customer support. Engineering applies powerful three-dimensional CAD/CAM techniques that seamlessly interface with the production systems; ensuring employees receive

detailed on-line work instructions. The vehicle data for each individual truck is centrally stored for guaranteed traceability, making it easy for dealers to check specifications and order parts – right down to the options fitted.

Product Development

The DAF Technical Centre offers comprehensive research development and testing facilities, including an anechoic chamber for noise measurements and a state-of-the-art engine laboratory. DAF also has an extensive proving ground for simulating road conditions so vehicle performance can be thoroughly tested. DAF Trucks delivers world-class vehicles designed in world-class development facilities by a world-class development team.

EcoDesign and environmental policy

DAF has had an environmental policy in place for over 10 years, covering all its activities, products, services and locations - including dealers. Its environmental care system is ISO 14001 approved. And DAF has achieved a 'Zero Waste to Landfill' status. Which means waste is either recycled, reprocessed, or used for generating energy. EcoDesign is the company's unique approach to environmentally responsible product design, and is concerned with ensuring that all DAF's products comply with the strictest environmental guidelines, from first concept to end-of-life recycling.



Advanced equipment and IT systems contribute to improved quality and increased efficiency.

***DAF uses the PACCAR Production System: right first time;
no waste of energy and materials; highest quality standards.***



DAF

XF

SEA SHIPPING

ZPMC

DAF's one-stop shop offers a total transport solution

With you all the way

Road transport is all about optimum efficiency, so DAF offers a total transport solution, designed to maximize earnings per kilometre. It is supported by a professional organisation and dealer network that helps customers choose the right vehicle, finance it, maintain it in perfect condition, and keep it running at all times.

DAF Trucks not only makes quality vehicles, but also has a first-class back-up organisation with more than 1,000 independent dealers in Europe. They provide support ranging from financial services to repair & maintenance contracts. Parts for truck and trailers are always available, supplied to workshops by PACCAR Parts Distribution Centres in the Netherlands, the United Kingdom, Spain and Hungary. Every week, over 3,000 shipments are made to dealers and customers across Europe and beyond – often within 24 hours.

DAF MultiSupport Repair & Maintenance contracts

Tailored to truck and customer needs DAF MultiSupport offers a fixed rate per kilometre for repair & maintenance, ensuring a perfectly maintained fleet without unexpected costs. DAF MultiSupport is more than just repair & maintenance; Customers benefit from increased vehicle availability and reduced administration. Thereby, DAF MultiSupport provides peace of mind and enables fleet operators to focus on their core business.

Tailor-made financial services

PACCAR Financial has over 50 years of experience in the transport industry and we understand your business needs. Our services include financing the total truck combination, R&M contracts and insurance. PACCAR Financial is available at all DAF dealer locations, providing one-stop access for trucks and financial help – including solutions for national and pan-European operators.

DAF International Truck Service (ITS)

If something unexpected should ever happen, one telephone call to DAF's ITS gets the truck rolling again with minimum delay. Often copied but never equalled, ITS is on stand-by day and night, 365 days a year. Experienced employees mobilize the DAF service organisation, handling language and financial issues to ensure that a stranded truck is back on the road with minimum delay.



A top-class support organization of more than 1,000 independent dealers.



DAF ITS: often copied but never equalled.



At DAF, we understand better than anyone else that a truck has to keep moving.

The XF series axle configuration overview

Rigids

FA	4 x 2	
FAR	6 x 2	Single mounted trailing axle
FAS	6 x 2	Dual mounted trailing axle
FAN	6 x 2	
FAT	6 x 4	
FAK	8 x 2	
FAD	8 x 4	

Tractors

FT	4 x 2		
FTP	6 x 2		
FTR	6 x 2	Single mounted trailing axle	
FTS	6 x 2	Dual mounted trailing axle	
FTG	6 x 2		steered axle
FTT	6 x 4		driven axle
FTM	8 x 4		trailing axle



PACCAR MX300

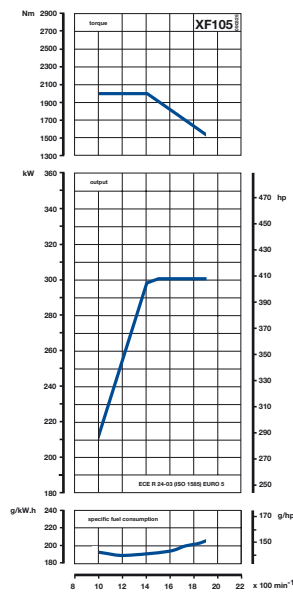

PACCAR MX340

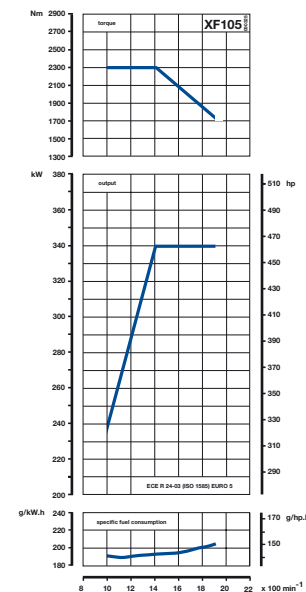

PACCAR MX375

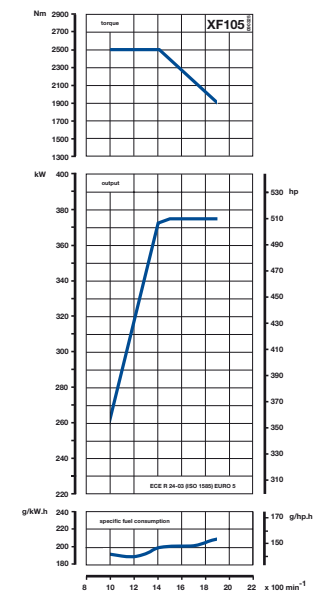

DAF XF105 Super Space Cab

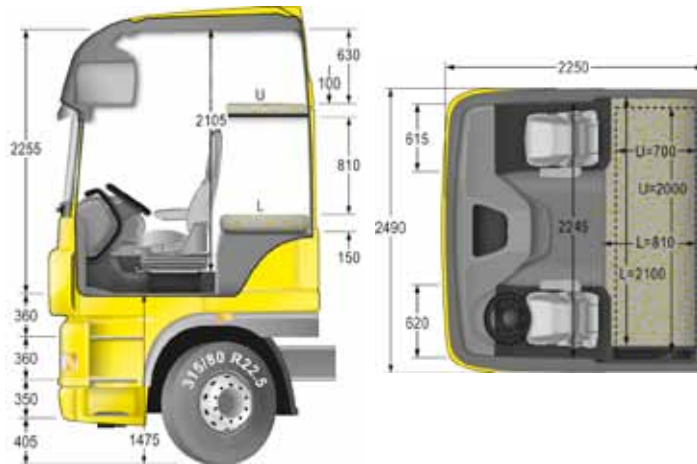

DAF XF105 Space Cab

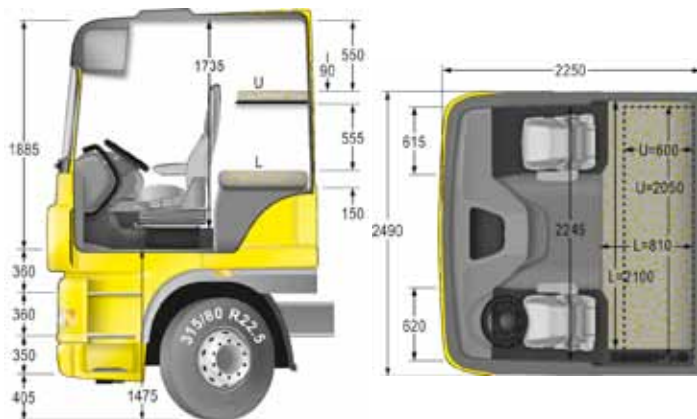

The XF105 engine overview

Engine Type	Performance	Torque	Emission level
PACCAR MX engine: 12,9 litre, six-cylinder, turbo intercooler, 4 valves per cylinder			
XF105.410	300 kW / 410 hp at 1500-1900 rpm	2000 Nm at 1000-1410 rpm	Euro 5 / EEV
XF105.460	340 kW / 460 hp at 1500-1900 rpm	2300 Nm at 1000-1410 rpm	Euro 5 / EEV
XF105.510	375 kW / 510 hp at 1500-1900 rpm	2500 Nm at 1000-1410 rpm	Euro 5 / EEV





The most modern product range on the market

A truck for every need

Every transport application has unique requirements, so every DAF vehicle is unique, built to order from a range of cabs, chassis, drive lines and axle configurations.

Three vehicle concepts – the XF105, CF and LF – one quality standard: the best. When ordering, the DAF sales specialist advises the customer using state-of-the-art software, ensuring the specifications exactly match the application.

Whatever the challenge, there's a DAF to meet it.

With a balanced selection of cabs, drive lines and axle configurations, there's a DAF truck that precisely matches your needs, whatever the application.



No rights can be derived from this publication.
DAF Trucks N.V. reserves the right to change
product specifications without prior notice.
Products and services comply with the European
Directives effective at the time of sale but may
vary depending on the country in which you are located.
For the most recent information,
contact your authorized DAF dealer.



ISO14001
Environmental
Management System



ISO/TS 16949
Quality
Management System

DAF Trucks N.V.
Hugo van der Goeslaan 1
P.O. Box 90065
5600 PT Eindhoven
The Netherlands
Tel: +31 (0) 40 21 49 111
Fax: +31 (0) 40 21 44 325
www.daf.com

DW14203006/HQ-GB:0512

driven by quality

DAF
A **PACCAR** COMPANY

